

THE EXPANDED INSTRUMENT SYSTEM: RECENT DEVELOPMENTS

David Gamper with Pauline Oliveros
Pauline Oliveros Foundation
PO Box 1956
Kingston, NY 12402
<dgamper@earthlink.net>, <paulineo@deeplisting.org>

Abstract

I demonstrate the current configuration and user interface of the Expanded Instrument System, an improvising performance environment for acoustic musicians used extensively by Pauline Oliveros and Deep Listening Band. The constraints from which this configuration emerged are discussed and provide the rationale for the design and implementation decisions made, including those for a custom MIDI interface for the vintage Lexicon PCM 42 delay.

I. Introduction

The Expanded Instrument System (EIS) is a performer controlled delay based network of digital sound processing devices designed to be an improvising environment for acoustic musicians. Since its presentation at the 1991 International Computer Music Conference [Oliveros and Panaiotis, 1991] the EIS has undergone a radical shift in implementation while maintaining its roots firmly in the work of Pauline Oliveros beginning in the late fifties [Oliveros, 1995]. In the current configuration each performer has appropriate microphones, a Macintosh computer running Opcode's Max program and a collection of sound processing electronic devices. Foot switches and "expression" type foot pedals are interpreted by programming in Max to control the signal routing from the microphones among the sound processors, as well as control certain functions of the processors themselves. Each of these set-ups is referred to as an EIS station. Sound outputs from each station are distributed to at least four speakers encircling the performance and audience space. On the station's computer screen [Figure 1], the performer sees a display of the available functions to be controlled and their current state. This is critical, because many of these functions are actually controlled by a single foot pedal, which is switched to control the desired function. This "multifunction pedal" keeps the number of pedals confronting the performer to a minimum. There is also a separate function which allows the performer to store and recall sets of function settings. Although the labels for the functions are necessarily cryptic due to screen size limitations combined with readability constraints, they have proved to be readily decoded with a little practice. In performance all functions can be controlled by foot pedals and a foot switch board, leaving the performers' hands free to play their instruments. For performers with a hand free, control can be switched to a MIDI fader box. Figure 2 is a block diagram of a basic EIS station.

II. Roots of the Current Configuration

Oliveros was one of my composition teachers and my Master's thesis advisor at the University of California, San Diego in the early 70's and I participated in her *Meditation Project*, an exploration of meditation technique in relation to music and musicians, [Oliveros, 1984] which she integrated into her series of *Sonic Meditations* and the development of Deep Listening. I had been composing with delays since getting my first tape recorder in the sixties. A natural partnership was formed when I began working with Oliveros again in 1989 and joined her Deep Listening Band the following year. At that time, all the sound processing in the Expanded Instrument System was centralized and manually controlled by two performers, vocalist Panaiotis and I on piano and winds, with the other performers (Oliveros on accordion, Stuart Dempster on trombone and didjeridu, and any guest musicians) having only limited control of their primary delays. The other performers sometimes wished they could change parameters or keep them the same when Panaiotis or I changed them. On the other hand, our mixing and routing duties meant that Panaiotis and I were sometimes not able to sound when we wanted. Although we experimented with various forms of more distributed control, none proved usable in performance.

When Panaiotis left the group in 1993, it was evident that I could not operate the system alone. We were already using the Polysonic Reson8 DSP multiprocessor [Barriere, Freed, Baisnee, and Baudot, 1989] with Max on a Macintosh Quadra 700 as its interface, and I had become used to Max as a programming and rapid prototyping environment. Our immediate need to distribute control to the other performers drove me to conceive a configuration I could implement relatively quickly while using inexpensive stock MIDI equipment. The solution proved worthwhile to Deep Listening Band and adaptable to many other combinations of performers. Since then, as Director of Technical Development for the Expanded Instrument System at the Pauline Oliveros Foundation, I have extended the

EIS to provide for guest musicians with limited learning time, adapted it to various compositional requirements, and have helped numerous composers and musicians explore it during extended installations and demonstrations.

The Lexicon PCM 42 remains the primary delay of the Expanded Instrument System because it provides the warmest replay of acoustic sound of any processor that we know. It also features a voltage controlled clock oscillator which allows a foot pedal to sweep the effective delay time over a three to one ratio of delay times of up to nine seconds. [Oliveros, 1995] Since the advent of fixed sampling frequencies needed for digital input and output, this combination of smooth changes of delay time and related pitch bending has been designed out of digital delays of equivalent sound quality. Until another instrument achieves these features the PCM 42 remains our delay of choice.

This also means that we have one foot firmly planted in the analog signal domain and must make extensive use of analog signal routing. We had been using Niche ACM MIDI controlled resistors for automated panning, and the addition of a Mackie 1604 mixer with Otto MIDI automation allowed me to extend performer control over analog signal routing. Our Lexicon PCM 70 digital processors were of MIDI vintage, giving me easy implementation of performer control of program selection and variable parameters. Although my new configuration meant that the PCM 42's and PCM 70's had to be allocated among the performers, the Reson8 could only be shared by way of its host computer. We have four channels of audio A/D and D/A to the Reson8, which runs six sample rate conversion programs on delay lines with full matrixing of samples among the processors. The basic program had been designed by Panaiotis to emulate some of the effects of the PCM 42, and although we quickly discovered that the sound quality suffered somewhat with "smooth" modulations, the addition of computer control was useful, especially in this new configuration. I used spare MIDI ports on the multi-port MIDI interfaces (Opcode Studio 4) at each additional station to send and receive MIDI data controlling the DSP processes for audio from those stations.

The need to add performer foot operated control over many functions led me to the multifunction pedal concept. The performer selects which function to control by toggling up or down the list of functions with a foot switch. I use the memory function of the display to solve the problem of a function suddenly jumping to the value where the expression pedal happens to be set by asking the performer to first move the pedal (value displayed at "Ped Out") to the value at which the function was last (value also displayed at "Hunt Last") at which time the "Hunt Last" indicator jumps to "Ped Out." [lower part of right window in Figure 1] Fortunately this turns out to be much easier to learn in practice than to explain in words.

Although each PCM 42 requires its own dedicated pedal for analog clock oscillator control, and other functions need a pedal controlling the multifunction program, I have maintained the use of separate dedicated pedals for input level control. This immediate access is an important consideration for an acoustic performer when the smallest sound can be expanded and sent out over multiple speakers.

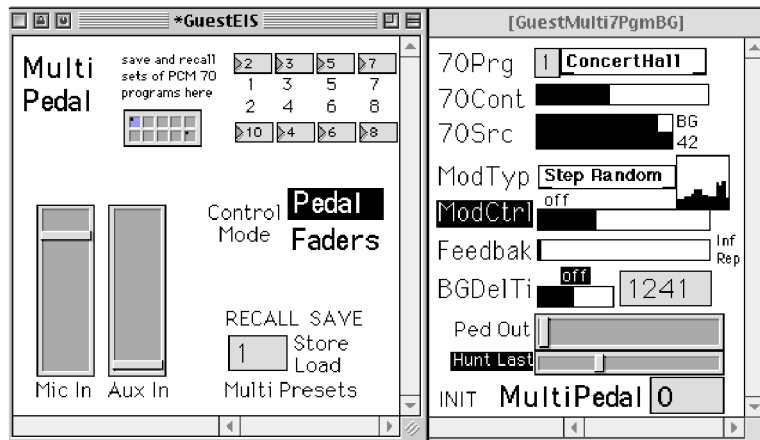

Figure 1. Computer screen read-out of basic Expanded Instrument System user interface, programmed in Opcode's MAX. The left window includes readouts of the volume control pedals, mapping of PCM 70 programs, selection of pedal or fader box control of the multifunction pedal, and information for using presets for the multifunction pedal. The right window displays multifunction pedal information, including the last values of each function and the function being controlled. User interfaces for more complex stations are conceptually similar, but may include two multifunction pedal screens controlling up to forty functions.

III. Recent Developments

In an earlier configuration, [Oliveros, 1995] modulation of the read/write sample rate of of the Reson8 delay programs was controlled through two functions suggested by front panel controls of the PCM 42 – a combination wave shape and depth control and a rate control. As with the use of the foot pedal on the PCM 42, this has the effect of modulating the pitch of whatever sound is being delayed. It soon becomes evident that leaving the depth and/or rate parameters unvaried can become very static musically. The modulation is more interesting when a more complex modulation function incorporating random variations is substituted. To implement this I programmed various modulation algorithms such that the user chooses the algorithm (“ModType” in Figure 1) and then varies some aspect of it (“ModCtrl”). The precision of control in the Reson8 program allows the use of just tuning intervals in two types of step wise modulation functions. Because the algorithm patches are modular, I can easily modify or replace them. One algorithm (named “LightningBox”) is actually an editable (though not in performance) sequence of the other algorithms. In the block diagram [Figure 2] the second PCM 42 can be a channel of the Reson8.

A solution to function proliferation is illustrated by the “70Src” function which controls the mix of the delay output signals fed to the PCM 70 effects processor (mostly used for adding ambiance effects.) As the control pedal is varied from minimum to maximum, first one output is increased to its maximum, then the other output, and finally the first is decreased to its minimum. Similar algorithms are used for other signal routing functions for more complex setups, including controlling input levels from multiple microphones with a single pedal.

I have extended the memory function of the multifunction pedal display to allow the user to store and load sets of function settings during performance, again using the switches on the MIDI pedalboard. Smoothing added to appropriate functions keeps abrupt jumps in values at bay. These presets are saved automatically and reloaded at the next startup, but sets of presets can be saved and recalled though standard Macintosh Save and Open dialog actions.

Our previous implementations of computer control of the vintage PCM 42 delay meant giving up the direct analog foot pedal control, a form of control for which Oliveros in particular has developed a considerable technique. Recently I have designed, and Bob Bielecki has engineered an interface which successfully implements this computer control. This interface, the BGBox, is a hybrid digital and analog system using MIDI for computer control, but retaining the smooth foot pedal control which is so much a part of the PCM 42’s use as the heart of the EIS. Extending hands-free functional control to the PCM 42’s has also enabled me to design simplified installations, such as the one demonstrated here, without giving up all of the more cumbersome Reson8’s advantages.

In this BGBox PCM 42 interface, we wanted to preserve the smoothness of the variability of the PCM 42’s voltage controlled clock oscillator. Although MIDI provides for double precision (14 bits) resolution, it is generally not feasible to quickly (over less than a fraction of a second) send a continuous stream of consecutive double precision values. A previous non-MIDI implementation using 8 bits through a serial port had sounded too discontinuous. We settled on 12 bits as adequate, and use a 12 bit D/A converter to translate digital data to the control voltage. To compromise with the data rates of MIDI, the BGBox retains 7 bit MIDI controller information, but fills in the intermediate values for 12 bit resolution with a counter controlled through two other MIDI controllers. The first sets a fixed rate of change for one data point to count to the next. The second turns on or off a function which sets the rate of change calculated from the time between the previous data points. Between these two options, very smooth modulation of the voltage controlled oscillator can be generated without too much MIDI overhead. For discrete step wise values, we use another MIDI controller to poke a value directly into the D/A converter. Because of the significant drift of the PCM 42’s clock oscillator, we decided 7 bits was enough useful resolution. To retain direct foot pedal analog control of the clock oscillator, the voltages from the computer control D/A converter and the foot pedal are summed after each are scaled through MIDI controlled amplifiers whose gains are set through two more MIDI controllers. Although not used in the basic EIS station demonstrated here, the proportions of control may be varied and the analog PCM 42 pedal now can have a sensitivity control.

Computer control of the feedback function is effected with another MIDI controlled amplifier which varies the gain in the feedback loop accessed through the feedback jack on the PCM 42. The infinite repeat function is also controlled through other MIDI controllers. These controls are incorporated in the “Feedback” function in Figure 1. Other MIDI controllers operate the two front panel buttons which increment and decrement the length of the digital delay memory (set by the user with the function “BGDeITi” in Figure 1.) Still another controller strobes the delay time display data back to the interface.

I have adapted the modulation algorithms used with the Reson8 for the different control range and smoothing options of the BGBox. Sadly, precise just intonation oriented modulations are not possible with the BGBox controlled PCM 42 due to temperature drift of its analog clock oscillator. Of course, new algorithms are sure to

emerge with future development and performance.

Adding computer control to the PCM 42 has meant a proliferation of functions to control. Not illustrated here is a “Switch” function which toggles between two multifunction pedal screens, almost doubling the number of functions. I have experimented with small modifications which add switching capabilities to a stock foot pedal and Bielecki is investigating instrument mounted controllers. Also planned is a real time sequencer function to allow a performer to record, save and playback controller manipulations in performance. As ever, the Expanded Instrument System will continue to evolve and be adapted to its users needs.

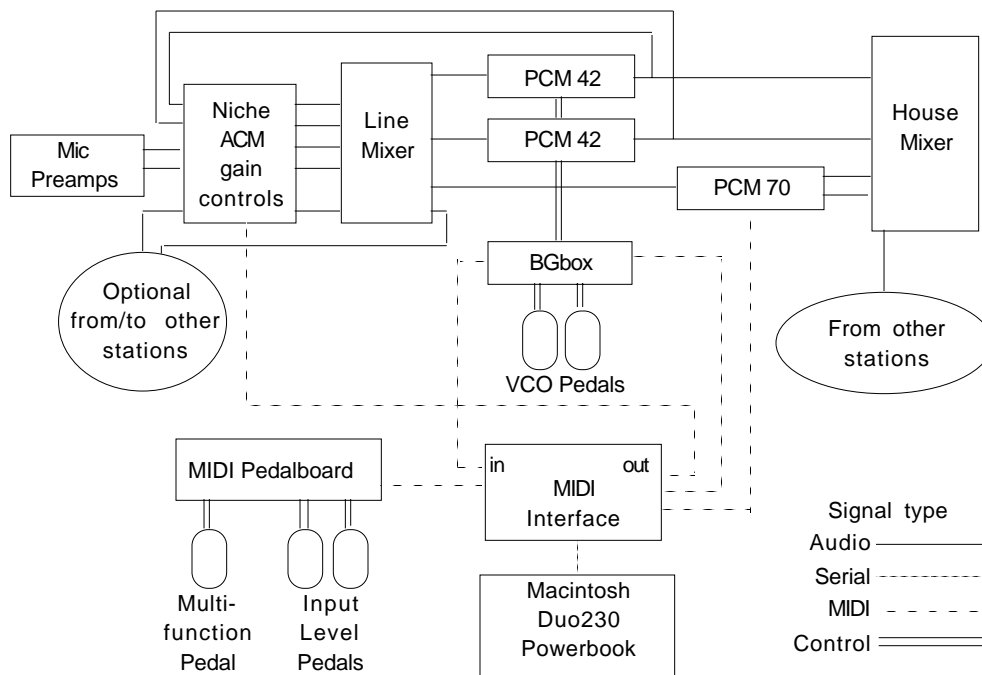

Figure 2. Block diagram of a basic Expanded Instrument System station – others are similar conceptually. The PCM 42 is an analog-controlled digital delay from Lexicon. The PCM 70 is a MIDI-controlled digital effects processor, also from Lexicon. The BGbox is a custom MIDI controlled interface which adds MIDI control of many of the PCM 42's front panel controls. The Mic Preamps and Line Mixer are sections of a Mackie 1202. The Niche ACM is a set of 8 MIDI controlled resistors used for gain control of audio signals. The MIDI Pedalboard is a Rolls MIDI Wizard foot switch board which also converts expression pedals to MIDI continuous controller data. The House Mixer distributes outputs to speakers surrounding the audience.

Acknowledgement

The Expanded Instrument System and Deep Listening Band are projects of the Pauline Oliveros Foundation, which holds trademarks for the names “Expanded Instrument System” and “Deep Listening.” More information and a discography can be found at <<http://www.deeplisting.org>>.

References

- [Barriere, Freed, Baisnee, and Baudot, 1989] Jean-Baptiste Barriere, Adrean Freed, Pierre-Francois Baisnee, and Marie-Dominique Baudot, “A Digital Signal Multiprocessor and a Musical Application,” *Proceedings of the International Computer Music Conference*, (Computer Music Association, 1989) pp. 17-20.
- [Oliveros, 1984] Pauline Oliveros, “On Sonic Meditation” and “Meditation Project,” *Software for People: Collected Essays 1963-1980* (Baltimore, MD: Smith Publications, 1984) pp. 138-164.
- [Oliveros, 1995] Pauline Oliveros, “Acoustic and Virtual Space as a Dynamic Element of Music,” *Leonardo Music Journal*, Volume 5, 19-22 (1995).
- [Oliveros and Panaiotis, 1991] Pauline Oliveros and Panaiotis, “Expanded Instrument System (EIS),” *Proceedings of the International Computer Music Conference*, (Montreal: 1991) pp. 404-407.